

## Sink Skin Double



Kitchen Sinks

Code: 4455 040



### DETAILS

Edge/Installation Type	Flush-mount   Top-mount
Material	AISI 304 stainless steel
Texture	Foster brushed
Base	80 cm
Dimensions	750 x 440 mm
Standard fittings	Fixing hooks, gasket, drain, overflow and siphon, boxed packing
Mixer holes	No standard holes
Built-in hole	View technical data sheet
Drainer	No

Width 75 cm

---

Bowl dimension 340x400mm

---

Number of bowls 2 bowls

---

Waste fitting Drain SPACE 3,5"

---

Notes: As the product consists of a single seamless steel surface with no gaps or interstices, the use of garbage disposal and waste fitting with automatic control is not permitted.

---

## FEATURES

**ONE SEAMLESS STEEL SURFACE** The waste-fitting and overflow are moulded on the sink. The product is therefore made out of one seamless steel surface, without gaps or interstices. A great plus in terms of hygiene.

---

**Deep bowls** This bowls reach an important depth, over 20 cm, thanks to the advanced production technology, that can be offer great capiciency and practicity in all the washing operations.

---

**High thickness** 1mm thick steel. A significant thickness, which guarantees the maximum sturdiness and durability.

---

**Perimetral overflow** The overflow is always a security on the Foster sinks that prevents the overflow of water in case of oversights. The perimeter drain solution improves aesthetics thanks to its square and essential shape.

---

**Save space system** Drain and siphon are designed to leave as much space as possible in the under-sink area, more and more useful today for theseparate waste collection systems.

---

**Small radius** Bowls with squared shapes with a modern design and an increased capacity, for a minimal aesthetics connected with an extreme practicity.

---

**Space waste fitting** The elegant SPACE steel cap closes the drain and leaves no visible residues collected in the basket below. Space also has a small footprint and allows the optimal use of the under-sink compartment.

---

## TECHNICAL DATA

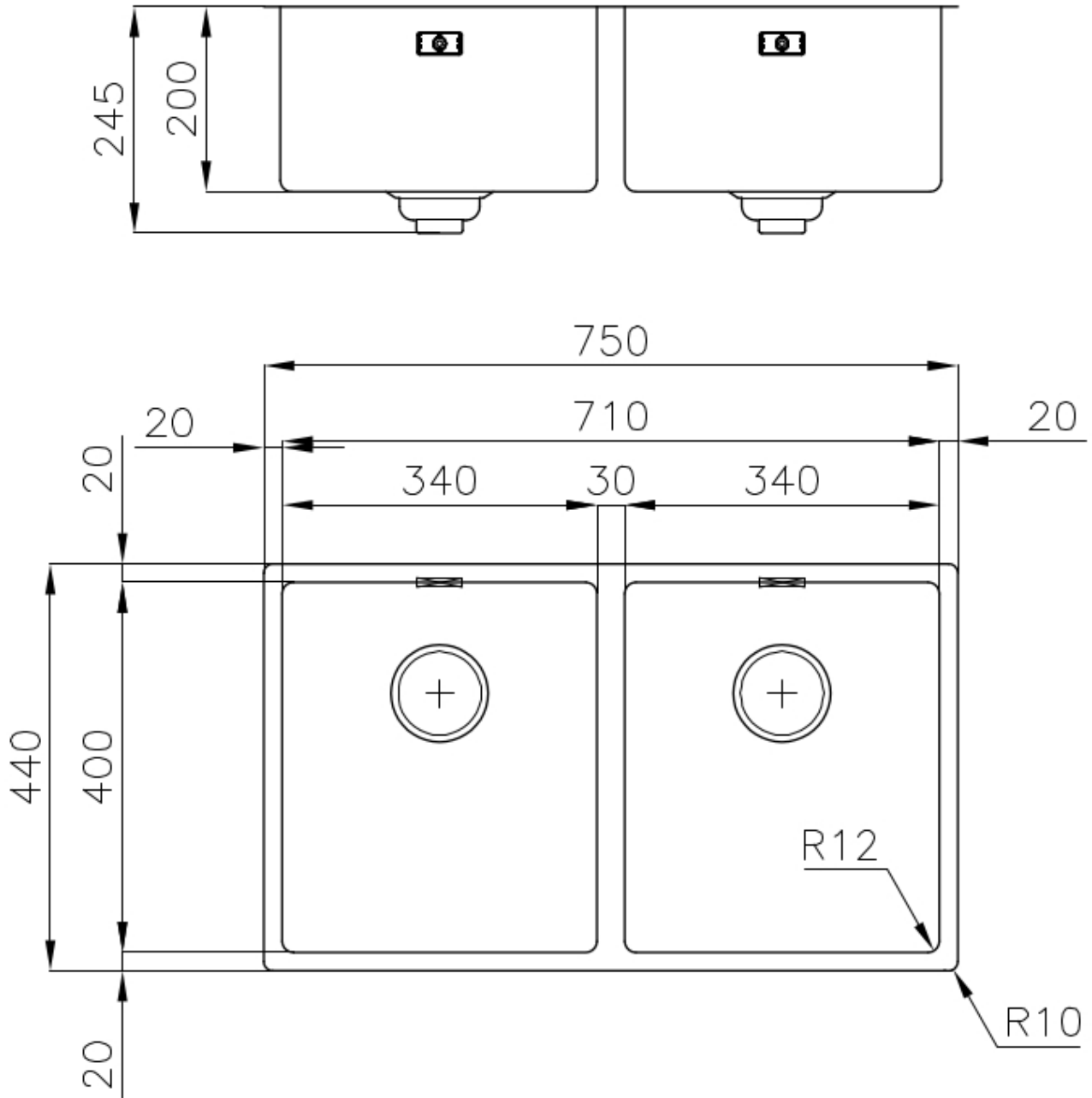

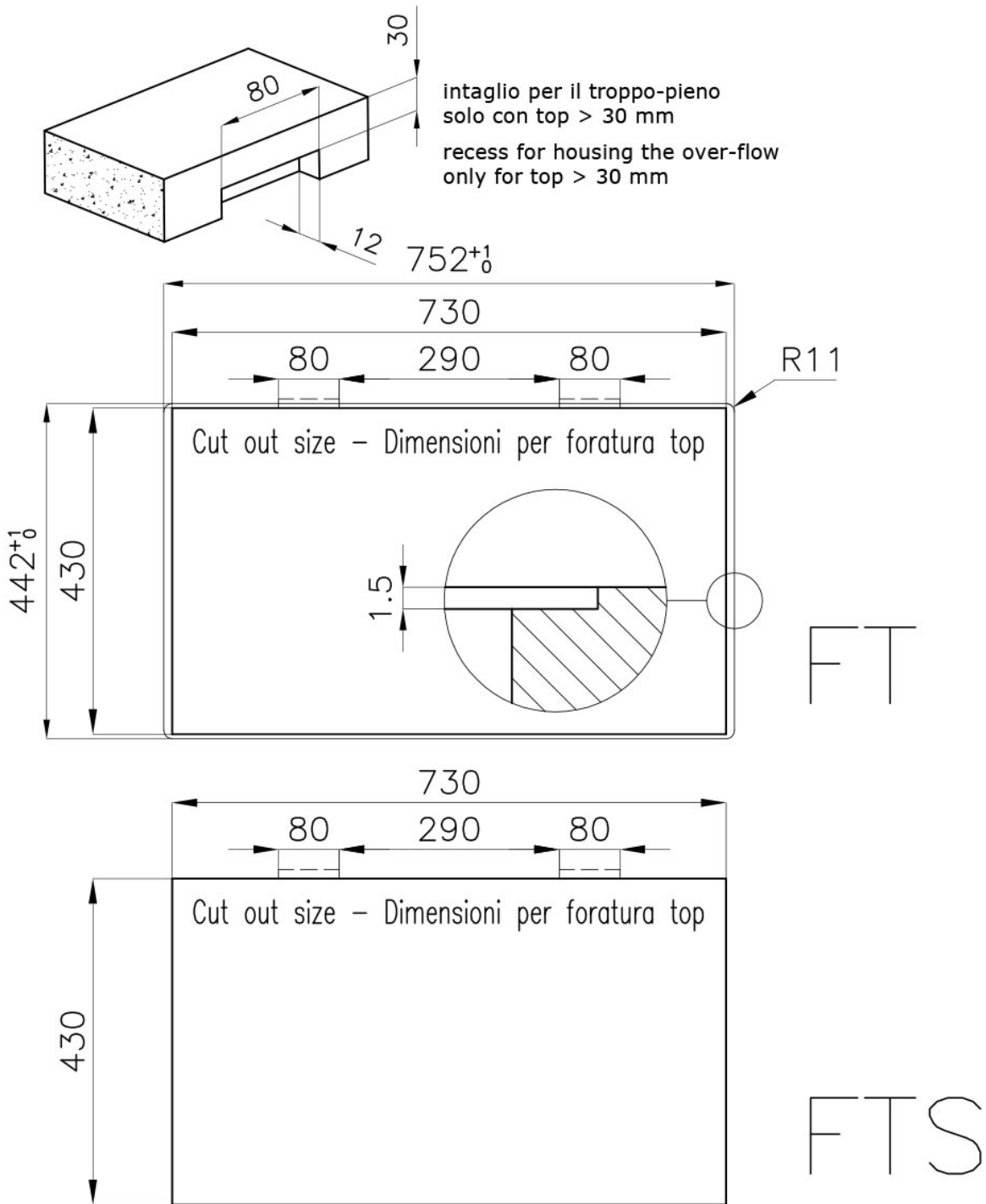

## GALLERY



## OPTIONAL ACCESSORIES



**Glass chopping board**  
8631 300



**HPDE Twin chopping board**  
8644 101



**Stainless steel plate rack**  
8100 154

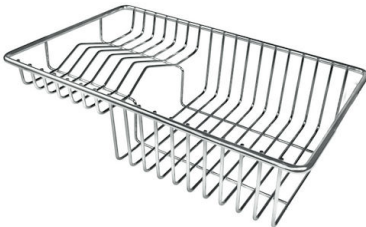

**Stainless steel plate rack**  
8100 303

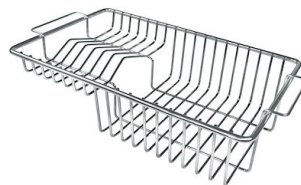

**Stainless steel plate rack**  
8100 201



**White bowl**  
8153 100

\* only in combination with the accessory  
8644 101



**Graters kit with ring-holder and food collection tray**

8159 101

\* only in combination with the accessory  
8644 101



**Iroko-wood sliding chopping board with stainless steel colander**

8644 044



**Stainless steel basket**

8611 000



**Stainless steel perforated tray**

8151 000

\* only in combination with the accessory  
8644 101

## RECOMMENDED PAIRINGS



**Mixer Tap Skin**

8424 100



**VELA PLUS satin**

8497 120



**VOLTA**

8491 100